

Status and Plan of the SoLID Software Framework

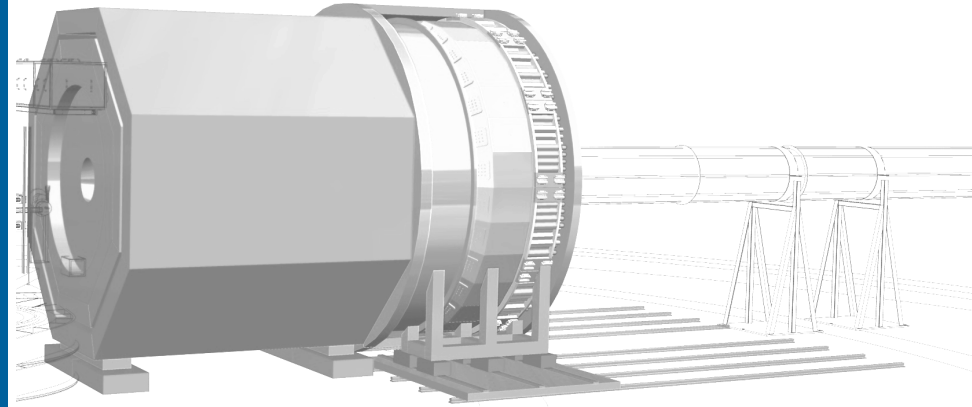

Chao Peng
Argonne National Laboratory
21 June 2024

Using EIC Software for SoLID

- Modern software toolchain
 - Modular, easy to implement SoLID-specific development
 - Designed to utilize HPC resources
 - Being maintained and improved by active developers from NP/HEP community
- Mutual Beneficial
 - Share development of digitization/reconstruction
 - Test and implementation of streaming, AI/ML in simulation/analysis

Software Framework Overview

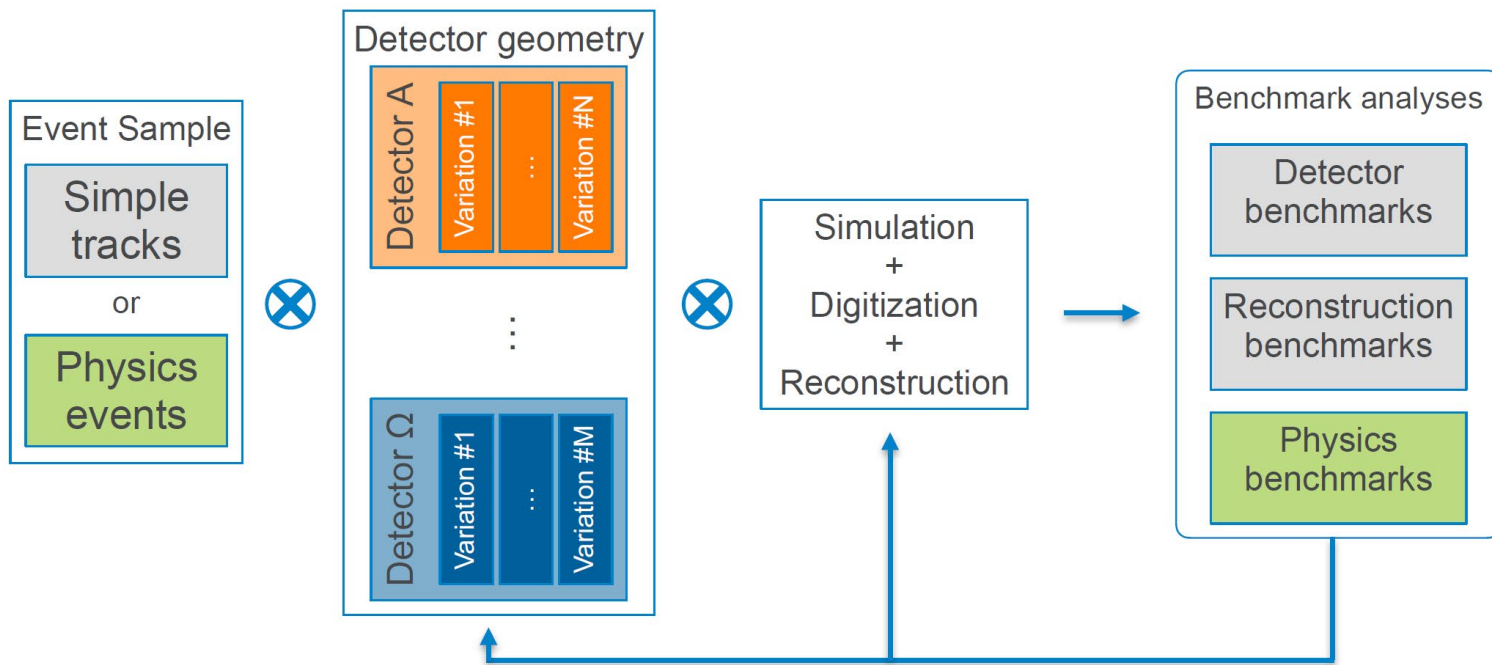

Figure courtesy: S. Joosten

Key Components of the Toolchain

- **EDM4hep**: Generic event data model for HEP
- **DD4hep**: a consistent detector description for simulation, reconstruction, and analysis
 - Geant4 geometry from plugin library
 - Configurable with xml file
- **ACTS**: Experiment-independent tracking toolkit for HEP in modern C++
 - Built-in support for DD4hep geometry description (via plugin)
- **Juggler/EICrecon**: Generic event processing framework

Data Model – EDM4hep

<https://github.com/key4hep/EDM4hep>

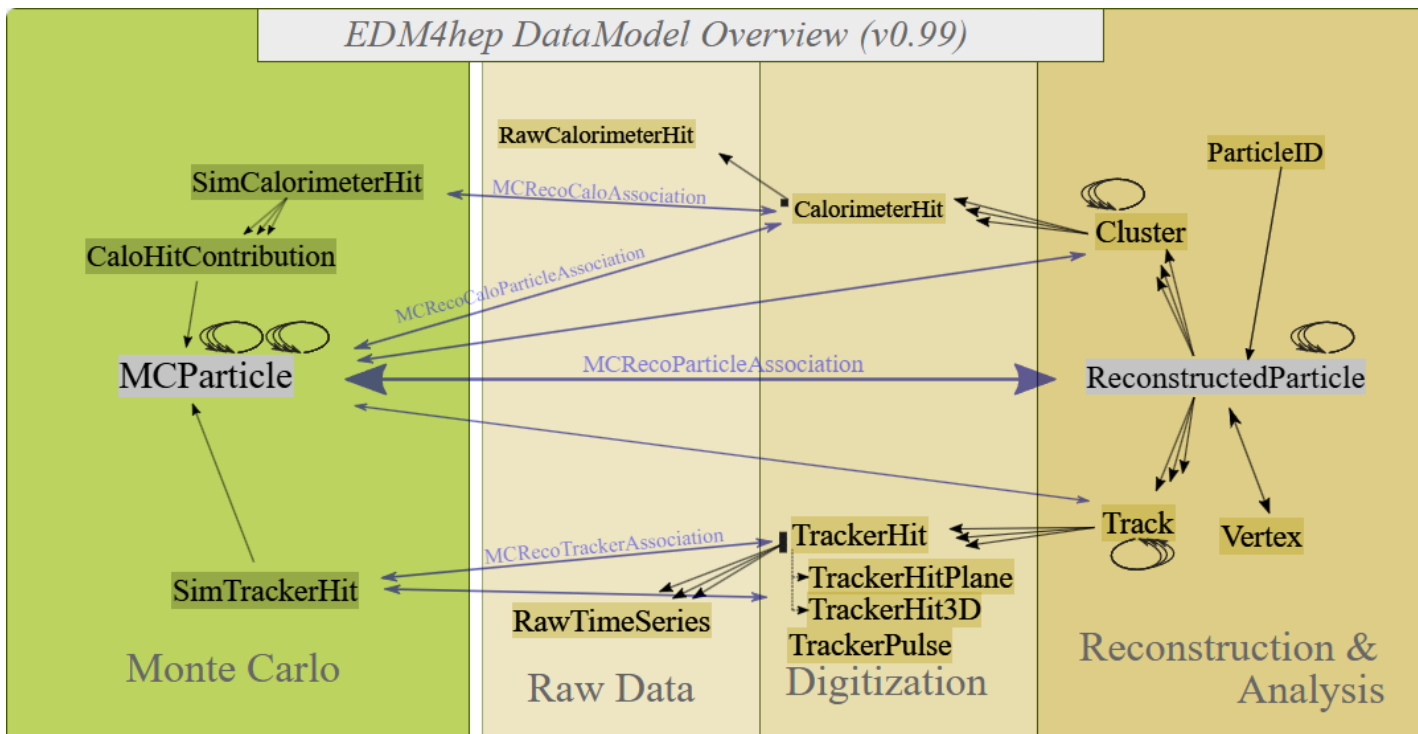



Geometry Description – DD4hep

<https://github.com/AIDAsoft/DD4hep>

- Full detector description (ROOT geometry libraries)
 - Geometry, materials, visualization, readout, alignment, calibration, etc
 - Parameterization with plugins (C++) + compact files (xml)
- Full experiment life cycle
 - Detector concept development and optimization
 - Construction
 - Operation
- Single-source detector description
 - Simulation (GEANT4), reconstruction , analysis

Generic Tracking - ACTS

<https://github.com/acts-project/acts>



- Key features
 - Tracking geometry description from manual or TGeo/**DD4hep** input
 - Simple event data model
 - Common algorithms for track propagation and fitting
 - Basic seed finding algorithms
 - Common vertexing algorithms

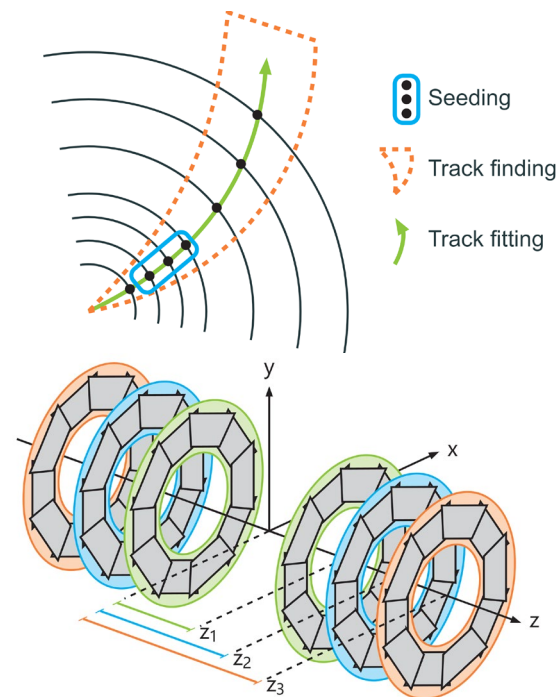

Talks from Shujie Li and Weizhi Xiong on Saturday

Event Processing Frameworks

- Juggler
 - Event processing framework based on Gaudi
 - Gaudi was developed for LHCb event processing
 - Concurrent event processing
 - Plugins for algorithms and services
- EICrecon
 - JANA based
 - Used by ePIC collaboration, in active development



<https://eicweb.phy.anl.gov/EIC/juggler>



<https://lhcb.github.io/DevelopKit/03a-gaudi>



<https://github.com/eic/EICrecon>

Developed algorithms can be used with both frameworks

SoLID Software Transition

- Transition to EIC software
 - From GEMC based simulation
 - To the modern software toolchain for simulation, event reconstruction, and analysis
 - EDM4hep + DD4hep + ACTS + Juggler/EICrecon
- Milestones
 - ✓ Implementation of SoLID geometry in DD4hep
 - Detector benchmarking and comparison study with original simulation
 - Reconstruction benchmarking and integrated reconstruction
 - Physics simulation and analysis

Geometries for Major Subsystems

https://github.com/JeffersonLab/solid_dd4hep

- Rough geometries have already been implemented in DD4hep
 - FAEC, LAEC
 - LGC, HGC
 - GEM trackers
 - Solenoid and some support structure (not shown)

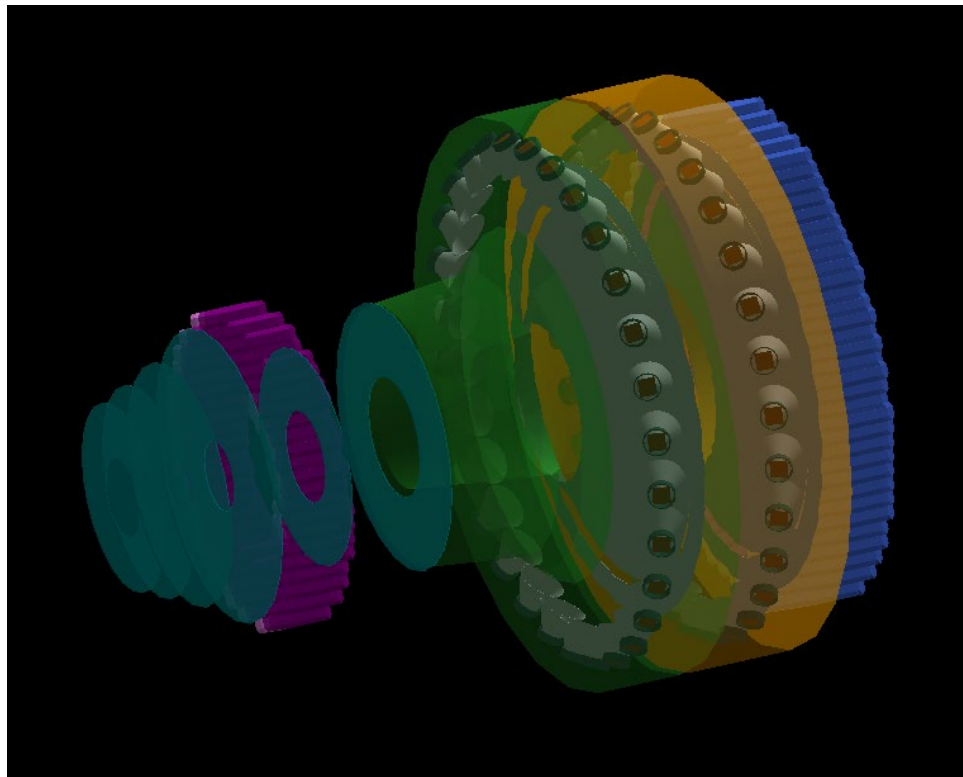

Geometries for Major Subsystems

https://github.com/JeffersonLab/solid_dd4hep

- Visualization tools implemented for geometry development and checks
 - GEANT4
 - DAWN
 - ROOT

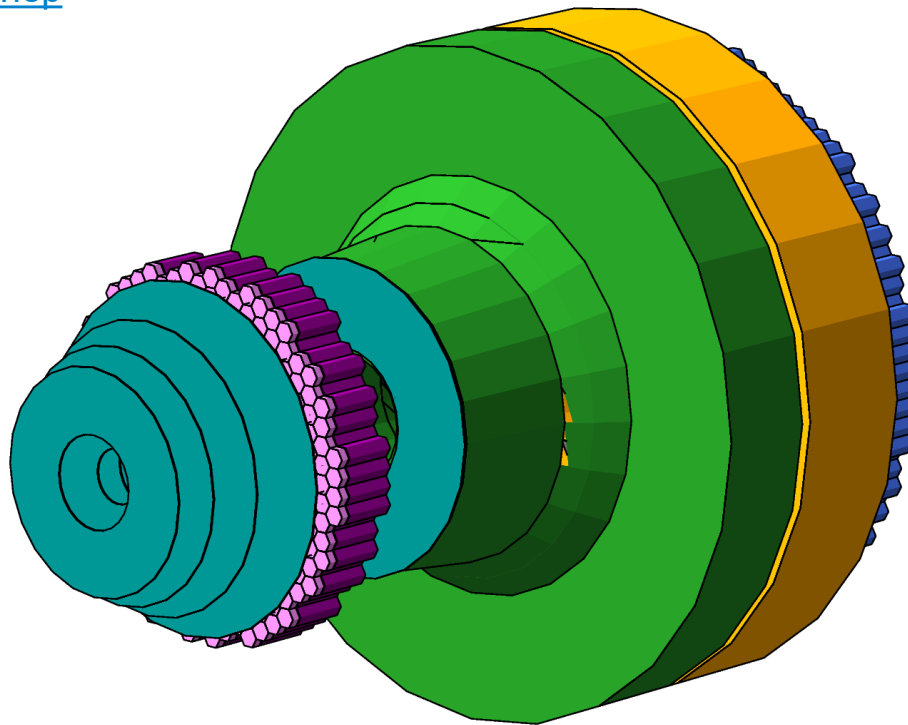

Geometry and Detector Benchmark: LGC

- Implemented according to the latest design and GEMC simulation
- Realistic simulation
 - Quantum efficiency
 - Reflectivity
 - Refractive indices of gases
- Detector benchmarking
 - Optical photon detection

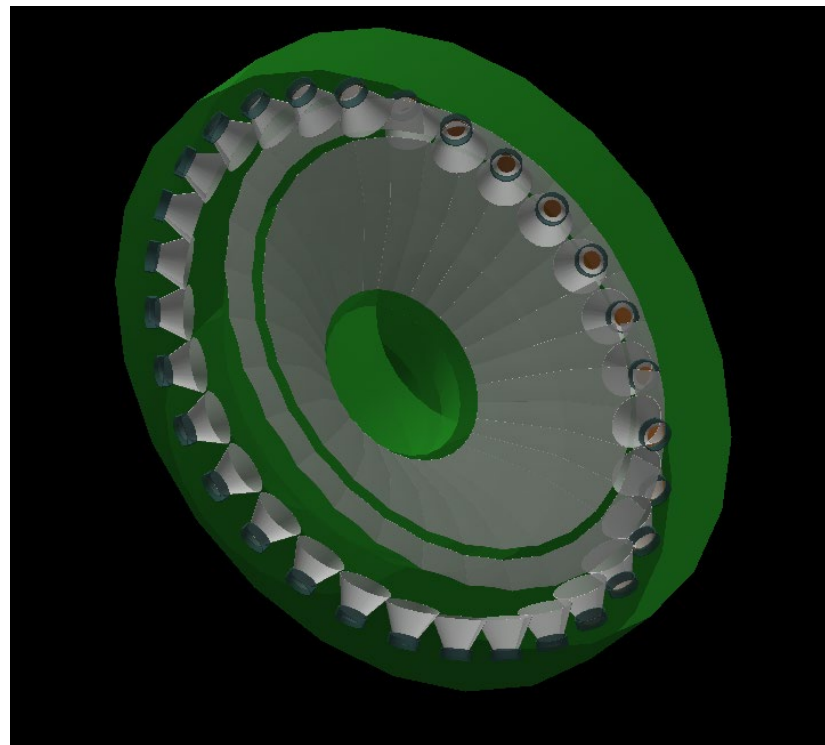

Geometry and Detector Benchmark: LGC

- Optical photon physics lists enabled in simulation
- Mirror surfaces implemented
 - Reflectivity curve
- Sensitive volume for optical photon detection
 - Optical photon destroys and deposit all energies
 - Q.E. vs. photon energy

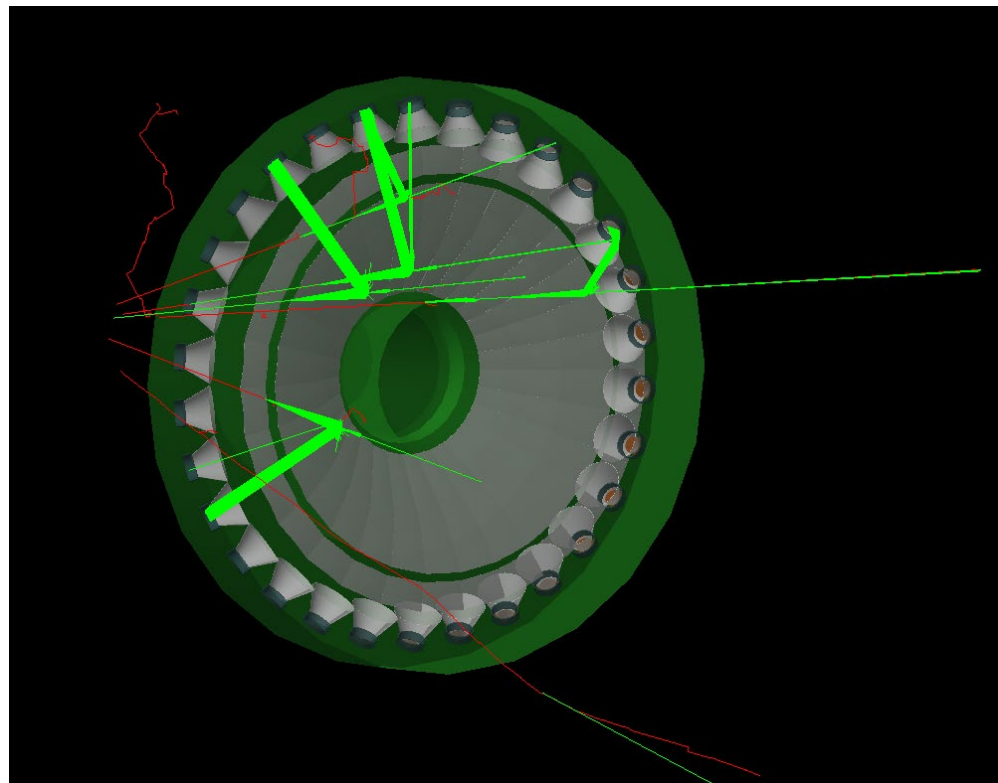

LGC Optics Simulation

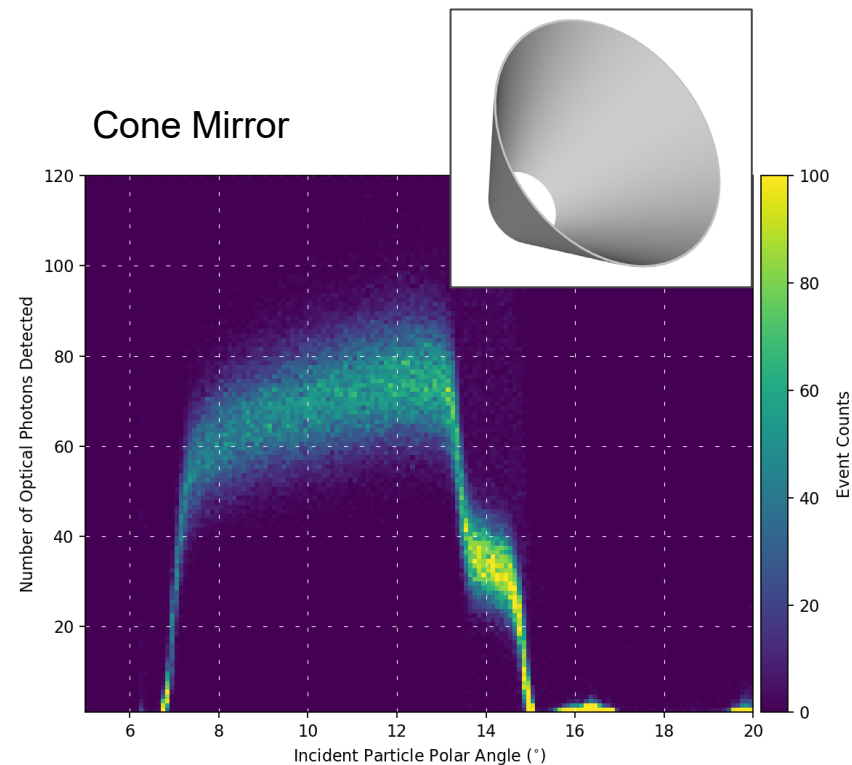
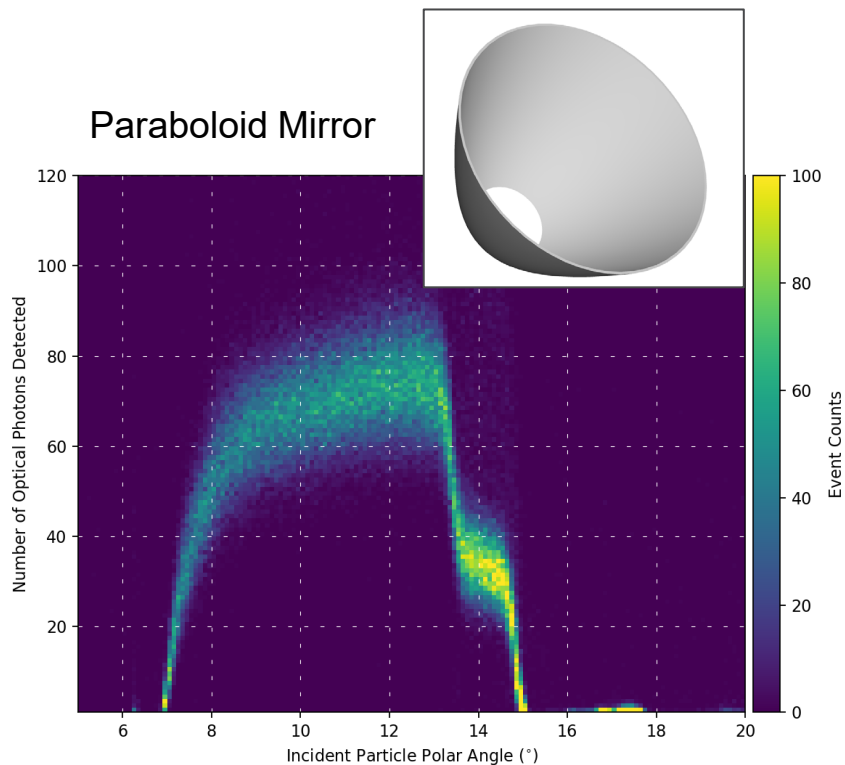

Plan for the Development

- Detector geometry implementation and benchmarking – **0.2 FTE**
 - LGC (Chao, Churamani), HGC (Zhiwen)
 - ECal, GEM Trackers, TOFs (Chao, Zhiwen)
- Reconstruction for individual detector subsystem – **0.5 FTE**
 - Clustering (Chao)
 - Cherenkov PID (Chao, Zhiwen)
 - Tracking (Weizhi, Shujie)
- Integrated reconstruction – **0.3 FTE**
 - Relative easier than ePIC due to a smaller number of subsystems
- Physics simulation and analysis
 - Approved experiments
 - Proposal development